

AC Josephson properties of phase slip lines in wide tin films

This article has been downloaded from IOPscience. Please scroll down to see the full text article.

2007 Supercond. Sci. Technol. 20 891

(<http://iopscience.iop.org/0953-2048/20/8/029>)

View [the table of contents for this issue](#), or go to the [journal homepage](#) for more

Download details:

IP Address: 129.16.87.99

The article was downloaded on 08/06/2010 at 14:40

Please note that [terms and conditions apply](#).

AC Josephson properties of phase slip lines in wide tin films

V M Dmitriev^{1,2}, I V Zolocheskii¹, E V Bezuglyi¹ and D S Kondrashev¹

¹ B Verkin Institute for Low Temperature Physics and Engineering, National Academy of Sciences of Ukraine, 61103 Kharkiv, Ukraine

² International Laboratory of High Magnetic Fields and Low Temperatures, 95 Gajowicka Street, 53-421 Wrocław, Poland

E-mail: dmitriev@ilt.kharkov.ua

Received 27 April 2007, in final form 3 July 2007

Published 26 July 2007

Online at stacks.iop.org/SUST/20/891

Abstract

Current steps in the current–voltage characteristics of wide superconducting Sn films exposed to microwave irradiation were observed in the resistive state with phase slip lines. The behavior of the magnitude of the steps with the applied irradiation power was found to be similar to that for the current steps in narrow superconducting channels with phase slip centers and, to some extent, for the Shapiro steps in Josephson junctions. This provides evidence for the Josephson properties of the phase slip lines in wide superconducting films and supports the assumption about the similarity between the processes of phase slip in wide and narrow films.

1. Introduction

The concept of phase slip line (PSL) formation by the transport current in wide superconducting films as a mechanism of their transition from the resistive vortex state to the normal state [1] suggests a similarity of the phase slip processes in the PSLs and in phase slip centers (PSCs) in narrow superconducting channels. It has been recognized (for a review see e.g. [2, 3]) that the initiation of PSLs is responsible for occurrence of alternate voltage steps and linear portions in the current–voltage characteristic (IVC) of wide films, similar to the IVC features associated with PSCs in narrow channels. Experimental investigations of the voltage distribution in the vicinity of the PSL [4] disclosed that the variations of the quasiparticle potential spread over the distance of the longitudinal electric field penetration depth l_E , which is also typical for a PSC. Theoretical results of analytical [5] and numerical [6] investigations of the PSL structure largely support suggested analogies between the PSLs and PSCs.

An important property of a PSC is oscillation of the order parameter in the PSC core with the Josephson frequency (AC Josephson effect) [7, 8]. The expected Josephson properties of PSLs were first examined in [9]; however, in this experiment, the vortex portion in the IVC of the sample was absent, which gives rise to a question about the interpretation of this sample as a wide film. Indeed, the width of the sample used in [9]

was $5 \mu\text{m}$, whereas the penetration depth of the normal-to-film magnetic field λ_{\perp} was $3\text{--}5 \mu\text{m}$, i.e. close to the film width. As shown in [3], if the film width w does not exceed the quadrupled penetration depth, i.e. at $w < 4\lambda_{\perp}(T)$, the transition of the superconducting film to the resistive phase slip state is similar to that in a narrow channel: it occurs as soon as the transport current approaches the value of the Ginzburg–Landau depairing current, bypassing the stage of the moving vortex lattice. Hence, strictly speaking, the experimental data in [9] were obtained for a narrow superconducting channel rather than for a really wide film.

In the present paper, we report the results of a series of experiments which demonstrate AC Josephson properties of PSLs for deliberately wide films with well pronounced initial vortex portions in the IVC. Following the results of theoretical [10] and experimental [3] investigations of the stability of the vortex state in wide films, we assume the absence of moving vortices in the phase slip state of the samples.

2. Experimental results

We investigate Sn films fabricated by a novel technique [3] which ensures minimum defects both at the film edges and in its bulk. The IVCs of the samples were obtained by a standard four-probe method. While measuring, the samples

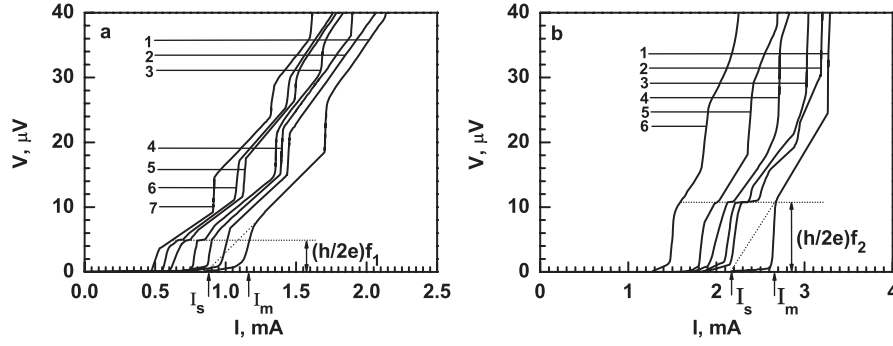

Figure 1. A family of IVCs for the films SnW12 at $T = 3.807$ K and $f_1 = 2476$ MHz (a) and SnW5 at $T = 3.744$ K and $f_2 = 5500$ MHz (b). For curve 1, the applied irradiation power equals zero; for the others it increases with the IVC number.

Table 1. Parameters of the film samples: L is the length, w the width, d the thickness of the sample, and l_i the electron mean free path.

Sample	L (μm)	w (μm)	d (nm)	$R_{4.2}$ (Ω)	R^\square (Ω)	T_c (K)	l_i (nm)	R_{300} (Ω)
SnW5	92	42	120	0.140	0.064	3.789	145	2.270
SnW12	90	18	332	0.038	0.008	3.836	466	1.880

were placed in a double screen of annealed permalloy. The parameters of some films are listed in table 1. The electron mean free path due to the scattering on impurities, l_i , was evaluated by the formula $l_i = l_{\text{ph}}(R_{300}/R_{4.2} - 1)$ [11, 12]. Here $l_{\text{ph}} = 9.5$ nm is the electron–phonon scattering length in Sn at room temperature [12], R_{300} is the film resistance at room temperature and $R_{4.2}$ is the residual film resistance.

Families of the IVCs for the SnW12 and SnW5 samples, (a) and (b), respectively, measured at different irradiation powers, are presented in figure 1. For the first IVC, the rf power is zero, while for the others it increases with the IVC serial number. We note that the inequality $w/\lambda_\perp(T) \geq 20$ is fulfilled for both films and their IVCs contain initial resistive regions caused by the vortex motion, i.e., both films can be unambiguously referred to as wide ones. The IVCs of the films on initiation of PSLs have the same shape as the IVC of a narrow channel on initiation of PSCs: they reveal abrupt voltage steps, cut-off current I_s at zero voltage, excess current at high voltages, and the sample resistance changes by a multiple: $R = nR_{d1}$, where R_{d1} is the dynamic resistance of a IVC linear portion corresponding to the first PSL and n is the number of PSLs in the film. Under the microwave irradiation, current steps occur in the IVCs at fixed voltage, proportional to the frequency f .

As soon as we suggest the phase slip processes to be similar in a narrow channel and in a wide film, it would be natural to use the experience obtained when investigating the AC Josephson properties of PSCs, considering the PSL as a source of the Josephson irradiation. Then the observed current steps can be identified as the Shapiro steps in the IVC of the Josephson irradiation source at the applied voltages [13]

$$V = \frac{nh}{2e}f \quad (n = 1, 2, \dots), \quad (1)$$

which are known to result from the interaction between the applied microwave field and the AC Josephson current.

We note that the experimental observation of the current steps, associated with the Josephson irradiation of the PSL, requires fulfilment of several essential conditions and exclusion of some side-effects. First, the current steps may also appear in the vortex state, as the result of mutual synchronization [14] between the applied irradiation and moving vortex chains. To avoid this, we choose high enough irradiation frequency, thus adjusting current step position (1) inside the voltage region of the dynamic PSL resistance in the IVC, where the state of the sample is known to be free of vortices [3]. At the same time, the frequency should be smaller than the lower frequency of occurrence of the superconductivity enhancement [15], which causes both the critical current and the magnitude of the voltage step on the PSL initiation to considerably enhance with increasing irradiation power. We found that in the presence of the enhancement effect the current step cannot be observed, because its expected position falls into the PSL voltage step. This essentially confines the maximum possible value of the irradiation frequency.

In its turn, the constraint to the highest frequency value imposes a limitation on the magnitude V_1 of the voltage step on initiation of the first PSL, which must be smaller than the voltage $hf/2e$ at which the current step occurs. This requires samples with large enough specific conductance, i.e. with comparatively large mean free path l_i . At first, we studied rather thick films with a large $l_i \sim 500$ nm, for example a SnW12 film, in which the magnitude of the first PSL voltage step is small enough, $V_1 \sim 6 \mu\text{V}$. For thinner films with smaller $l_i \sim 150$ nm, e.g. for a SnW5 film, we also managed to observe the current step, though we had to increase the irradiation frequency because of the increase in the PSL voltage step $V_1 \sim 10 \mu\text{V}$. As is evident from figure 1, even at a maximum possible frequency, the PSL voltage step in the IVC with no microwave field applied still remains larger than the expected voltage value for the occurrence of the current step, $V_1 > hf/2e$. However, while the irradiation power increases, the values of the critical current and the voltage step decrease, providing a possibility for observation of the current step in the region of the dynamic PSL resistance.

Figure 2 shows the dependence of the first current step I_{dc} on the rf current $I_{\text{rf}} \propto \sqrt{P}$. For the dc voltage source,

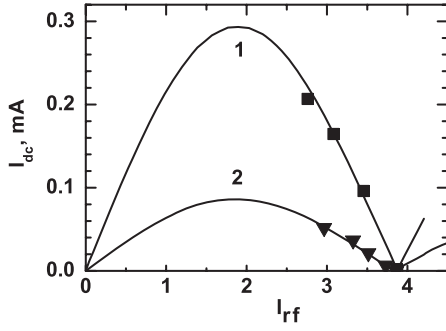

Figure 2. The amplitude I_{dc} of the first current step in the IVC as a function of the amplitude of the rf current $I_{rf} \propto \sqrt{P}$ in units of $hf/2eR_{d1}$: SnW5 sample—■, $T = 3.744$ K, $f = 5500$ MHz, $R_{d1} = 0.018 \Omega$, $I_J = 0.259$ mA; SnW12 sample—▼, $T = 3.807$ K, $f = 2476$ MHz, $R_{d1} = 0.015 \Omega$, $I_J = 0.075$ mA. Curves 1 and 2—theoretical results.

the dependence of the current step amplitude on the applied ac voltage is known to follow the Bessel function [16]. However, in practice, both the impedance of a microwave oscillator and the resistance of the dc source are usually larger than the impedance of the Josephson oscillator. In our experiments, the dynamic resistances of the PSL were $R_{d1} = 0.018 \Omega$ for SnW5 and $R_{d1} = 0.015 \Omega$ for SnW12, i.e., much smaller than the resistances of the microwave oscillator (50Ω) and the dc current source (470Ω). Since the sizes of our samples are small compared to the electromagnetic field wavelength (the film length is $\sim 10^{-4}$ m and the maximum wavelength is $\sim 10^{-2}$ m), we suggest that the microwave irradiation generates a spatially homogeneous rf current passing through the sample, $I_{rf} \propto \sqrt{P}$ (P is the irradiation power), although its absolute value was not measured.

In such a case, the assumption of given current applied to a PSL will be more adequate, and the equation of the resistive model of the Josephson junction [17, 18] can be used for description of the time dependence of the phase difference φ . For low-capacitance junctions, this equation reads

$$\frac{I_{rf}}{I_J} \sin \Omega \tau + \frac{I_{dc}}{I_J} = \frac{d\varphi}{d\tau} + \sin \varphi. \quad (2)$$

Here the dimensionless time and frequency are given by $\tau = \frac{2eR_{d1}I_J}{\hbar} t$ and $\Omega = \frac{hf}{2eR_{d1}I_J}$; I_J is the maximum Josephson current passing through the junction.

Theoretical dependences of the current step I_{dc} on the amplitude of I_{rf} obtained by numerical solution of (2) are shown in figure 2 by solid lines. As noted in [19], the time evolution of the phase φ under the microwave irradiation, and hence the behavior of the current step, essentially depends on the dimensionless frequency Ω : at $\Omega \gg 1$, the dependence of the step amplitude on the rf power, obtained in a framework of the resistive model (2), approaches the result of the given voltage model [16]. In our case, the dimensionless frequency is rather high, $\Omega = 2.44$ for SnW5 and $\Omega = 4.55$ for SnW12, which indicates the validity of both models for the description of our experimental data. Numerical simulations for these particular values of Ω also confirm this conclusion.

In figure 2, the rf current amplitude is expressed in units of $hf/2eR_{d1}$. Since only relative changes in I_{rf} can be

measured, the absolute values of I_{rf} were evaluated assuming the theoretical value of I_{rf} to be equal to the experimental one at the point where $I_{dc} = 0$. Another adjustable parameter is the amplitude of the Josephson current I_J through the PSL: by fitting the theoretical curve $I_{dc}(I_{rf})$ to the experimental points, we obtain $I_J = 0.26$ mA for the SnW5 sample and $I_J = 0.075$ mA for SnW12. Such low values of the superconducting current compared to the dissipative and critical currents have also been suggested in the theoretical PSL model [5]. Estimations of the Josephson irradiation power from the PSL by formulae $P = (I_{dc}^{max})^2 R_{d1}$ [20] (I_{dc}^{max} is the maximum magnitude of the current step) and $P = I_J^2 R_{d1}$ give almost the same results: $P_{SnW12} \approx 10^{-10}$ W for SnW12 and $P_{SnW5} \approx 10^{-9}$ W for SnW5, in agreement with the Josephson irradiation power from PSC [20] within an order of magnitude.

Since the current step occurs at a certain finite value of the rf power when the lower edge of the linear IVC portion approaches the voltage value $hf/2e$ (see figure 1), only a descending branch of the whole dependence $I_{dc}(I_{rf})$ was detected in the experiment, as obvious from figure 2. We also note that a part (from initiation to disappearance) of only one ‘period’ of the expected oscillating dependence [16] of the current step on the irradiation power was observed; the step does not reappear when the rf power further increases. A similar effect was found in the study of current steps in the IVCs of whiskers with PSCs [20]; the reason for this is as yet unknown.

In our experiments, we managed to detect only the first (main) Shapiro step corresponding to the integer $n = 1$ in (1). The absence of the steps associated with higher harmonics, $n > 1$, is a common feature of the experiments on the superconducting films [7] and whiskers [8, 20]. The authors of these papers have no explanation for this fact. In our case we suppose that the most obvious reason for this is that the expected positions of the higher current steps fall into the PSL voltage steps, as seen from figure 1(b) for sample SnW5; for a similar reason, the steps with $n = 2, 3$ were not observed in [8]. For sample SnW12 (see figure 1(a)), the current step at $n = 2$ might in principle be detected at the linear IVC portion; however, as follows from the analysis in [16], the amplitude of the n th step decreases with increase in n at fixed magnitude of the rf power. Thus, due to the relatively small value of the main step in this case, the value of the second step may appear beyond the accuracy of our measurements. It should also be noted that the intrinsic dynamics of the weak link in a PSC or a PSL is much more complicated and considerably affected by the microwave power, in contrast to that of artificial (‘hand-made’) Josephson junctions. Thus a more reasoned explanation of the experimental deviations from the results of the traditional theory of the Shapiro steps requires creation of a consistent theory of the self-organized Josephson weak links such as PSCs and PSLs under external irradiation.

3. Conclusions

In conclusion, current steps resulting from the interaction between the intrinsic Josephson irradiation of phase slip lines and the applied electromagnetic field were first observed in the current–voltage characteristics of deliberately wide

superconducting films, whose transition to the resistive state with phase slip lines is preceded by creation of a vortex state. The dependence of the current step magnitude on the rf power is similar to the behavior of the current steps, associated with the phase slip centers in narrow superconducting channels. This gives experimental evidence that the nonstationary properties of phase slip lines and phase slip centers are largely identical.

Acknowledgments

The authors express their thanks to T V Salenkova for technical assistance and E V Khristenko for helpful discussions.

References

- [1] Volotskaya V G, Dmitrenko I M, Musienko L E and Sivakov A G 1981 *Sov. J. Low Temp. Phys.* **7** 188
- [2] Dmitrenko I M 1996 *Low Temp. Phys.* **22** 648
- [3] Dmitriev V M and Zolocheskii I V 2006 *Supercond. Sci. Technol.* **19** 342
- [4] Dmitrenko I M, Volotskaya V G and Sivakov A G 1983 *Low Temp. Phys.* **9** 76
- [5] Lempitskiy S V 1986 *Sov. Phys.—JETP* **90** 793
- [6] Weber A and Kramer L 1991 *J. Low Temp. Phys.* **84** 289
- [7] Skocpol W J, Beasley M R and Tinkham M 1974 *J. Low Temp. Phys.* **16** 145
- [8] Tidecks R and Minnigerode G V 1979 *Phys. Status Solidi a* **52** 421
- [9] Sivakov A G, Glukhov A M, Omelyanchouk A N, Koval Y, Muller P and Ustinov A V 2003 *Phys. Rev. Lett.* **91** 267001
- [10] Aslamazov L G and Lempitskiy S V 1983 *Sov. Phys.—JETP* **63** 442
- [11] Rugheimer N M, Lehoczy A and Brisco C V 1967 *Phys. Rev.* **154** 414
- [12] Harper F E and Tinkham M 1968 *Phys. Rev.* **172** 441
- [13] Shapiro S 1963 *Phys. Rev. Lett.* **11** 80
- [14] Anderson P W and Dayem A H 1964 *Phys. Rev. Lett.* **13** 195
- [15] Dmitriev V M, Zolocheskii I V, Salenkova T V and Khristenko E V 2005 *Low Temp. Phys.* **31** 957
- [16] Grimes C C and Shapiro S 1968 *Phys. Rev.* **169** 397
- [17] McCumber D E 1968 *J. Appl. Phys.* **39** 2503
- [17] McCumber D E 1968 *J. Appl. Phys.* **39** 3113
- [18] Stewart W C 1968 *Appl. Phys. Lett.* **12** 277
- [19] Russer P 1972 *J. Appl. Phys.* **43** 2008
- [20] Kuznetsov V I and Tulin V A 1998 *Sov. Phys.—JETP* **86** 745